

Australian Men's Shed Association
SHOULDER TO SHOULDER

AMSA Men's Shed Health & Safety Manual

'Safe Use' documentation

January 2020

13. SAFE USE OF SPECIFIC EQUIPMENT

ONLY APPROVED OPERATORS ALLOWED TO USE MACHINERY. CHECK GENERAL SAFETY RULES BEFORE OPERATION.

a. *Circular Bench Saw*

Risks:

1. Dangerous saw blade
2. Woodchips & dust in eyes
3. Noise

Safety Controls:

1. Wear GOGGLES
2. Wear EAR MUFFS
3. Use PUSH STICKS

Procedure:

1. Adjust height of safety guard to suit thickness of timber to be sawn
2. Set height of saw blade
3. Check Dust Extractor is ON & Gate OPEN
4. Check position of Fence
5. Switch saw ON
6. Cut timber using PUSH STICKS for small pieces & at the end of the cut
7. Wait for saw to STOP before picking up the pieces
8. Turn saw OFF and close Extractor Gate
9. Clean up



ONLY APPROVED OPERATORS ALLOWED TO USE MACHINERY. CHECK GENERAL SAFETY RULES BEFORE OPERATION.

b. Sliding Compound Saw

Risks:

1. Woodchips in eyes
2. Can cut fingers on blade
3. Kickback from work piece.
4. Noise

Safety Controls:

1. Wear GOGGLES/EAR MUFFS
2. Keep fingers clear
3. Ensure blade at full speed before commencing cut

Procedure:

1. Check guard is in place & functioning satisfactorily
2. Turn on Dust extractor
3. Place timber flat onto cutting bed & clamp into position against fence
4. For long cut pull saw back - keep well above the timber
5. Switch "On" - hold button down until blade has reached full speed
6. Lower and PUSH blade through timber - do NOT pull to cut
7. Release 'On' switch - wait for blade to stop
8. Lift saw & return it to its rest position
9. Remove work piece
10. Clean up



ONLY APPROVED OPERATORS ALLOWED TO USE MACHINERY. CHECK GENERAL SAFETY RULES BEFORE OPERATION.

c. Small Compound Saw

Risks:

1. Woodchips in eyes
2. Can cut fingers on blade
3. Kickback from work piece
4. Noise

Safety Controls:

1. Wear GOGGLES/EAR MUFFS
2. Keep fingers clear
3. Ensure blade at full speed before commencing cut

Procedure:

1. Check guard is in place & functioning satisfactorily
2. Turn on Dust extractor
3. Place timber flat onto cutting bed & clamp into position against fence
4. Switch 'On' - hold button down until blade has reached full speed
5. Lower and PUSH blade down through timber
6. Release 'On' switch - wait for blade to stop
7. Lift saw & return it to its rest position
8. Remove work piece
9. Clean up.



ONLY APPROVED OPERATORS ALLOWED TO USE MACHINERY. CHECK GENERAL SAFETY RULES BEFORE OPERATION.

d. Band Saw

Risks:

1. Sawdust in eyes
2. Noise
3. Can cut fingers on blade

Safety Controls:

1. Wear GOGGLES/EAR MUFFS
2. Lower guard to just clear work
3. Do not Trap the blade
4. Use push sticks - not fingers

Procedure:

1. Turn on extractor
2. Lower guard to just clear job- turn saw on
3. Move timber slowly onto blade, following design lines on timber
4. Do not trap the blade or go backwards through the cut
5. For complicated patterns use multiple cuts at different angles
6. If the blade jams - SWITCH OFF before moving the work piece
7. Keep Hands, Fingers & Arms away from the blade
8. Switch 'Off' at the machine & wait for blade to stop
9. Remove work piece
10. Clean up



ONLY APPROVED OPERATORS ALLOWED TO USE MACHINERY. CHECK GENERAL SAFETY RULES BEFORE OPERATION.

e. Table Scroll Saw

Risks:

1. Risk of entanglement
2. Wood Dust in eyes/Noise
3. Saw blade oscillating at high speed

Safety Controls:

1. Eliminate loose clothing/long hair
2. Wear safety glasses/ear muffs
3. Keep hands clear of saw blade

Procedure:

1. Adjust saw blade tension as required
2. Switch on and wait for blade to reach full speed
3. Adjust work piece table and guides
4. Ensure dust extraction on and shut off gate is 'open'
5. Always feed the work slowly into the blade
6. Guide work piece carefully, blade may break
7. Switch off at machine- not at the wall
8. When blade motion ceases, clean up



ONLY APPROVED OPERATORS ALLOWED TO USE MACHINERY. CHECK GENERAL SAFETY RULES BEFORE OPERATION.

f. Router Bench

Risks:

1. Woodchips in eyes
2. Rotating cutter very dangerous
3. Kickback from work piece
4. Noise

Safety Controls:

1. Wear GOGGLES/EAR MUFFS
2. Keep fingers clear of Cutter
3. Wait until Bit rotation stops
4. Follow correct cutting direction

Procedure:

1. Ensure cutter bit is tightly locked in the chuck & free to rotate
2. Lock at the correct height using machine lock & adjustment lock nuts
3. Ensure guards are in place
4. Switch 'On' - allow to reach full speed
5. Check dust extraction is 'On'
6. Hold wood firmly to table - feed edge to cutter - beware of kickback
7. Always feed the work against the direction of rotation of the bit
8. Use repeated small cuts rather than one deep cut
9. Switch off at the machine (not wall) - wait until the bit stops rotating
10. Remove work piece
11. Clean up



ONLY APPROVED OPERATORS ALLOWED TO USE MACHINERY. CHECK GENERAL SAFETY RULES BEFORE OPERATION.

g. Drill Press

Risks:

1. Shavings in Eyes
2. Clothes/hair caught in machine
3. Chuck key left in - can throw out when machine starts

Safety Controls:

1. Wear GOGGLES
2. Wear HAIR COVER
3. Keep HANDS away from drill bit
4. Clamp down work piece

Procedure:

1. Lock drill bit in chuck using chuck key
2. Locate drill bit over target mark. If possible clamp down the work
3. Turn on machine - wait for full speed
4. Using manual lowering arm, move drill through material, backing off to clear swarf if necessary
5. Do not move material during the drilling operation
6. Lift drill to its rest position, turn off & wait until rotation of the bit stops
7. Remove work piece
8. Clean up



ONLY APPROVED OPERATORS ALLOWED TO USE MACHINERY. CHECK GENERAL SAFETY RULES BEFORE OPERATION

h. Belt Sander & Disc Grinder

Risks:

1. Risk of entanglement
2. Wood Dust in eyes/Noise
3. Belt/Disc rotating at high speed

Safety Controls:

1. Eliminate loose clothing/long hair
2. Wear safety glasses/ear muffs
3. Keep hands clear of belt/disc
4. Ensure table secure

Procedure:

1. Adjust disc table as required
2. Switch on and wait for belt/disc to reach full speed
3. Adjust work piece gauges and guides
4. Ensure dust extraction on and shut off gate is 'open'
5. Always feed the work against the rotation of the belt
6. Hold Work piece lightly in position on belt/disc- beware of 'kick back'
7. Switch off at machine- not at the wall
8. When belt rotation stops, clean up



ONLY APPROVED OPERATORS ALLOWED TO USE MACHINERY. CHECK GENERAL SAFETY RULES BEFORE OPERATION.

i. Wood Lathe

Risks:

1. Risk of entanglement
2. Wood Chips in eyes/Noise
3. Work/Chuck rotating at speed
4. Work piece can fly out at start-up

Safety Controls:

1. Eliminate loose clothing/long hair
2. Wear safety glasses/ear muffs
3. Keep hands clear of work/chuck.
4. Check work piece position, centre and rotation of direction prior to start

Procedure:

1. Seek instruction if not fully familiar with the wood lathe
2. Adjust and centre the work piece before work
3. Ensure chuck installed correctly and adjusted for work piece
4. Lock Tail Stock and Tool Rest in position
5. Set rotation speed and direction appropriate for the work
6. Ensure dust extraction on and shut off gate is “open”. Position chip collector
7. Switch on and wait for work to reach set speed
8. Make small cuts with appropriate hand tool or chisel
9. Keep work area as clear as possible and free of large quantities of chips
10. Switch off at machine then at the wall if finished work for the day
11. Clean up



ONLY APPROVED OPERATORS ALLOWED TO USE MACHINERY. CHECK GENERAL SAFETY RULES BEFORE OPERATION.

j. Spindle Moulder

Risks:

1. Wood Chips in eyes/Noise
2. Cutters rotating at high speed
3. Striking
4. Kickback from work piece

Safety Controls:

1. Wear safety glasses/ear muffs
2. Keep fingers clear of cutters
3. Ensure guards are in place
4. Wait for cutter to stop
5. Ensure tooling is secure in spindle
6. Follow correct cutting direction

Procedure:

1. Ensure that the cutter tooling is secure in the spindle
2. Adjust work piece gauges and guides
3. Ensure guards are in place
4. Ensure dust extraction on and shut off gate is 'open'
5. Switch on and wait for cutter to reach full speed
6. Always feed the work against the rotation of the cutter
7. Hold work piece in position against guides- beware of 'Kick Back'
8. Use push sticks where required for small work pieces
9. Switch off at machine. Not at the wall
10. When cutter rotation stops, remove work piece
11. Clean up



ONLY APPROVED OPERATORS ALLOWED TO USE MACHINERY. CHECK GENERAL SAFETY RULES BEFORE OPERATION.

k. Planer/Thicknesser

Risks:

1. Risk of entanglement
2. Wood Chips in eyes/Noise
3. Cutters rotating at high speed
4. Striking
5. Kickback from work piece

Safety Controls:

1. Eliminate loose clothing/long hair
2. Wear safety glasses/ear muffs
3. Keep hands clear of cutters
4. Ensure guards are in place
5. Do not stand behind work piece
6. Follow correct cutting direction

Procedure:

1. Adjust depth of cut for light pass-make small cuts
2. Adjust work piece gauges and guides
3. Ensure guards are in place
4. Ensure dust extraction on and shut off gate is 'open'
5. Switch on and wait for cutter to reach full speed
6. Always feed the work against the rotation of the cutter
7. Hold Work piece in position against guides-beware of 'Kick Back'
8. Use push sticks where required for small work pieces
9. Switch off at machine- not at the wall
10. When cutter rotation stops, remove work piece
11. Clean up



ONLY APPROVED OPERATORS ALLOWED TO USE MACHINERY. CHECK GENERAL SAFETY RULES BEFORE OPERATION.

l. Planer/Jointer

Risks:

1. Risk of entanglement
2. Wood Chips in eyes/Noise
3. Cutters rotating at high speed
4. Injury to hands
5. Kickback from work piece

Safety Controls:

1. Eliminate loose clothing/long hair
2. Wear safety glasses/ear muffs
3. Keep hands clear of cutters
4. Ensure guards are in place
5. Do not pass hands over cutter
6. Do not stand behind work piece

Procedure:

1. Adjust depth of cut for light pass- make small cuts
2. Adjust work piece gauges and guides
3. Ensure guards are in place
4. Ensure dust extraction on and shut off gate is 'open'
5. Switch on and wait for cutter to reach full speed
6. Always feed the work against the rotation of the cutter
7. Hold Work piece in position against guides. Beware of 'kick back'
8. Use push sticks where required for small work pieces
9. Switch off at machine - not at the wall
10. When cutter rotation stops, remove work piece
11. Clean up



ONLY APPROVED OPERATORS ALLOWED TO USE MACHINERY. CHECK GENERAL SAFETY RULES BEFORE OPERATION.

m. Mini Milling Drilling Machine

Risks:

1. Risk of entanglement
2. Injury, cutting, stabbing etc
3. Tool rotating at high speed
4. Striking injury
5. Swarf in eyes/Noise

Safety Controls:

1. Eliminate loose clothing/long hair
2. Machine isolated before adjustment
3. Keep hands clear of tooling
4. Check work piece & tooling are secure
5. Wear safety glasses/ear muffs

Procedure:

1. Seek instruction if not fully familiar with the Mini Drill/Mill
2. Ensure rotation direction set and correct
3. Secure work piece to the work table
4. Ensure that vertical axis assembly set upright or to appropriate angle
5. Select the right cutting tool for the job
6. Adjust and secure tooling in chuck and position
7. Switch on and wait for chuck to reach full speed. Adjust speed as required
8. Engage tooling smoothly and slowly- make small cuts
9. Switch off at machine - not at the wall
10. When cutter rotation stops, remove work piece
11. Clean up



ONLY APPROVED OPERATORS ALLOWED TO USE MACHINERY. CHECK GENERAL SAFETY RULES BEFORE OPERATION.

n. Panbrake/Folder/Guillotine & Roll

Risks:

1. Injury, cutting, stabbing etc
2. Striking injury
3. Shearing injury
4. Crushing injury

Safety Controls:

1. Wear gloves to prevent cuts from sharp material off-cuts.
2. Take care handling blades
3. Ensure material clamps adjusted
4. Keep hands clear of blades and rolls
5. Secure machine and work

Procedure:

1. Seek instruction if not fully familiar with the folder/guillotine
2. Ensure work piece within tolerances for this machine
3. Material maximum for shear/brake/fold 1mm steel. (30" wide)
4. Position work for fold, shear or roll
5. Test machine motion and clamping prior to full operation
6. Apply steady rotation to the handles. Assistance may be required for some jobs
7. When machine action stops, remove work piece
8. Clean up



ONLY APPROVED OPERATORS ALLOWED TO USE MACHINERY. CHECK GENERAL SAFETY RULES BEFORE OPERATION.

o. Metal Lathe

Risks:

1. Risk of entanglement
2. Injury, cutting, stabbing etc
3. Chuck rotating at high speed
4. Striking injury
5. Swarf in eyes/Noise

Safety Controls:

1. Eliminate loose clothing/long hair
2. All guards in position.
3. Machine is electrically isolated before adjustment
4. Keep hands clear of chuck
5. Check work piece & tooling are secure
6. Wear safety glasses/ear muffs

Procedure:

1. Seek instruction if not fully familiar with the AL60 metal lathe
2. Ensure guards are in place
3. Ensure rotation direction set and correct
4. Secure work piece in the chuck and lock
5. Select the right cutting tool for the job
6. Adjust and secure tooling and tail stock in position
7. Switch on and wait for chuck/work to reach full speed
8. Engage tooling smoothly and slowly - make small cuts
9. Switch off at machine - not at the wall
10. When cutter rotation stops, remove work piece
11. Clean up



p. Wood Turning Lathe

What should you do before using a wood turning lathe?

- A wood turning lathe can be dangerous if not used properly.
 - Read the owner's manual carefully.
 - Make sure you understand instructions before attempting to use any tool or machine. Only experienced and trained lathe operators should be allowed to operate lathes.
 - Learn the applications and limitations before use.
 - Refer to Woodworking Machines - General Safety Tips for general safety precautions.
-

What safety procedures should you follow when using a wood turning lathe?

- Wear safety glasses or goggles, or a face shield (with safety glasses or goggles) to protect yourself from flying chips.
- Wear hearing protection that is suitable for the level and frequency of the noise you are exposed to in the woodworking area.
- Wear a dusk mask when dust is generated (e.g., during sanding operations).
- Wear protective footwear when required.
- Work in well-lighted area.
- Before the lathe is turned on, ensure that all clamps and fittings are secure and that the work piece is free to turn.
- Use stock free of defects.
- Hold tools firmly with both hands and against the tool rest.
- Hold the stock securely on the faceplate or between the centres.
- Use only furnished or approved tools.
- Use sharp, well-maintained chisels and gouges.
- Select a speed that is appropriate for the job. Operate the lathe at a low speed and use a moderate cut depth to prevent splinters from flying out during roughing operations. The actual speed of the lathe depends on type of wood, a diameter of stock, nature of work being done and type of tool used.
- Adjust tool rests so that they are parallel and as close as possible to the stock. They should also be set high enough so that tools will cut into the wood slightly above the centre of the work being turned.
- Remove the tool rest when sanding or polishing.
- Use appropriate tools to hold the sand paper or emery paper whenever possible. Examples include a 'nut cracker' or the paper fixed to a piece of flat wood. If you must use your hands always hold the paper in a way that will not allow the paper to catch, pull or entangle around the stock.

- To make a faceplate turning, the one hand steadies the tip of the chisel, which holds the edge against the tool rest while the other hand guides the tool. Keep the tip of the chisel held higher than the handle.



What should you avoid when working with a woodturning lathe?

- Do not wear gloves, loose clothing, rings or jewellery around the neck that can hang outside one's clothing. Clothing should be comfortable but not so loose that it can catch on the machine or get entangled with any rotating parts or the wood being turned; shirts should be tucked in and long hair tied back.
- Do not leave a running lathe unattended - leave only after the lathe has been turned off and it has come to a complete stop.
- Do not use makeshift tools.
- Do not use stock containing checks, splits, cracks, or knots.



q. Woodworking Machines

What should you do before using woodworking machines?

- Woodworking tools can be dangerous if not used properly.
- Only use woodworking machines that you have been trained to use properly and safely.
- Read the owner's manual carefully.
- Make sure you understand instructions before attempting to use any tool or machine. Ask questions if you have any doubts about doing the work safely.

What safety procedures should you follow when using woodworking machines?

- Always wear safety glasses or goggles, or a face shield (with safety glasses or goggles).
- Wear hearing protection that is suitable for the level and frequency of the noise you are exposed to in the woodworking area. If you have trouble hearing someone speak from three feet away, the noise level from the machine is too high. Damage to hearing may occur.
- Use gloves to protect hands from splinters when handling wood but do not wear them near rotating blades and other machinery parts where the gloves can catch.
- Wear protective footwear when required.
- Make sure the guard is in position, is in good working condition, and guards the machine adequately before operating any equipment or machine. Check and adjust all other safety devices.
- Make sure the equipment is properly grounded before use.
- Check that keys and adjusting wrenches are removed from the machine before turning on the power.
- Inspect stock for nails or other materials before cutting, planing, routing or carrying out similar activities.
- Make sure that all machines have start and stop buttons within easy and convenient reach of an operator. Start buttons should be protected so that accidental contact will not start the machine. A collar around the button 3 to 6 mm (1/8 to 1/4 inch) above the button is recommended.
- Ensure that all cutting tools and blades are clean, sharp, and in good working order so that they will cut freely, not forced.
- Turn the power off and unplug the power cord (or lock out the power source) before inspecting, changing, cleaning, adjusting or repairing a blade or a machine. Also turn the power off when discussing the work.
- Use a "push stick" to push material into the cutting area. Jigs are also useful in keeping hands safe during cutting procedures. Keep hands out of the line of the cutting blade.
- Clamp down and secure all work pieces when drilling or milling.
- Use good lighting so that the work piece, cutting blades, and machine controls can be seen clearly. Position or shade lighting sources so they do not shine in the operator's eyes or cause any glare and reflections.

- Ensure that the floor space around the equipment is sufficient to enable you to machine the size of work piece being processed safely without bumping into other workers or equipment.
- Use extension tables or roller supports for large workpieces. Supports should be placed on both sides (infeed and outfeed).
- Woodworking machines should be fitted with efficient and well-maintained local exhaust ventilation systems to remove sawdust or chips that are produced.
- Electric power cords should be above head level or in the floor in such a way that they are not tripping hazards.
- Keep work area free of clutter, clean, well swept, and well lit. Spills should be cleaned up immediately. Floor areas should be level and non-slip. Good housekeeping practices and workplace design will reduce the number of injuries and accidents from slips, trips, and falls.

What should you avoid when working with woodworking machines?

- Do not wear loose clothing, work gloves, neckties, rings, bracelets or other jewellery that can become entangled with moving parts.
- Avoid awkward operations and hand positions where a sudden slip could cause your hand to move into the cutting tool or blade.
- Do not remove sawdust or cuttings from the cutting head by hand while a machine is running. Use a stick or brush when the machine has stopped moving.
- Do not use compressed air to remove sawdust, turnings, etc. from machines or clothing.
- Do not leave machines running unattended (unless they are designed and intended to be operated while unattended). Do not leave a machine until the power off is turned off and the machine comes to a complete stop.
- Do not try to free a stalled blade before turning the power off.
- Do not distract or startle an operator while he or she is using woodworking equipment.
- Horse play should be prohibited. It can lead to injuries.

r. Safe Use of Radial arm saw

What should you do before using a radial arm saw?

- A radial arm saw can be dangerous if not used properly.
 - Read the owner's manual carefully.
 - Make sure you understand instructions before attempting to use any tool or machine.
 - Learn the applications and limitations before use.
-

What safety procedures should you follow when using a radial arm saw?

- Wear safety glasses or goggles, or a face shield (with safety glasses or goggles).
- Wear hearing protection that is suitable for the level and frequency of the noise you are exposed to in the woodworking area.
- Wear protective footwear when required.
- Feed stock against the direction of the blade (the blade should move downward when viewed by the operator).
- Only use saw blades rated at or above the speed of the saw arbour. (An arbour is the attachment from motor to blade)
- Use only the accessories designed for that specific saw and application.
- Ensure the guard consists of two parts:
 - Upper hood type that covers arbour
 - Lower guard that rides on the stock, adjusting automatically to the thickness being cut.
- Stand on the handle side when cross cutting. Pull the cutting head with the hand nearest the handle and manoeuvre the stock with the other hand.
- Make sure the hand holding the stock is never in line with the blade.
- Return the cutting head completely to the back of the saw table after each cut. The saw should be designed so that the blade will not move forward under its own weight or if the machine is vibrating.
- When ripping, make sure the overall length of the saw table (both infeed and outfeed) is twice the length of the longest pieces of timber.
- When ripping, make sure that the stock is fed against the direction of the blade (from the side where the saw blade rotates upward toward the operator). The blade should extend slightly into the table. The motor head must be locked at the correct height and angle.
- Clamp stock to the table on one side of the saw blade, when making mitre, bevel or compound mitre cuts. Clamping prevents the wood from sliding along the fence during the cut.
- Turn off the saw when making any adjustments or changes in the set up.

- Make measurements by placing the wood to be cut against the stop gauge. When measuring with a tape measure or ruler is necessary, turn off the saw until the measuring is complete.

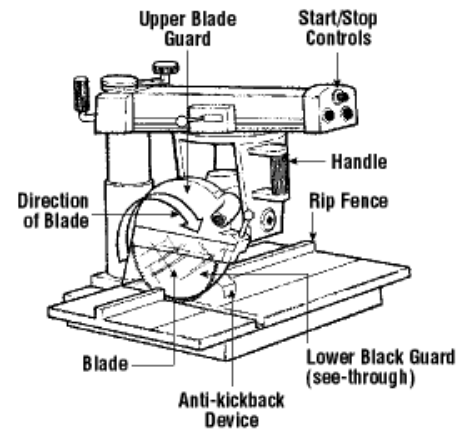

What should you avoid when working with a radial arm saw?

- Do not use radial arm saws for ripping unless the spreader (riving knife) and anti-kickback devices are provided and properly adjusted.
- Do not take your hand away from the operating handle unless the cutting head is behind the fence.
- Do not remove the stock from a saw table until the blade has been returned to its "resting" position at the back of the saw table. Use a stick or brush to remove scrap from the saw table.
- Do not cut "free hand". Use the back guide or fence, or other device to keep the workpiece from moving.
- Do not use cracked or dull blades.
- Do not leave a running saw unattended - leave only after the saw has been turned off and it has come to a complete stop.

s. Table Saw

What should you do before using a table saw?

A table saw can be dangerous if not used properly.

- Read the owner's manual carefully.
 - Make sure you understand instructions before attempting to use any tool or machine.
 - Learn the applications and limitations before use.
-

What safety procedures should you follow when using a table saw?

Wear safety glasses or goggles, or a face shield (with safety glasses or goggles).

- Wear hearing protection that is suitable for the level and frequency of the noise you are exposed to in the woodworking area.
- Wear protective footwear when required.
- Pay particular attention to the manufacturer's instructions on reducing the risk of kickback (when the wood can be violently thrown back toward the operator).
- Choose proper blades for the type of work being done.
- Keep blades clean, sharp, and properly set so that they will cut freely without having to force the work piece against the blade.
- Use the guards provided with the saw or ones designed for use with the saw that you are using. Keep them in place and in good working condition.
- Use a guard high enough to cover the part of the blade rising above the stock and wide enough to cover the blade when it is tilted. The blade height should be set so it does not extend more than about 3 mm (1/8 in) above the height of the piece being cut.
- Ensure that the fence is locked in position after the desired width has been set.
- Hold the work piece firmly down on the table and against the fence when pushing the wood through.
- Ensure that there is adequate support to hold a work piece; use extension tables or roller supports at the side or back for larger pieces. If an assistant is at the back (outfeed) end of the saw, an extension table should be in place so the back edge is about 1.2 m (4 ft) from the saw blade. The assistant should wait for the work piece to reach the edge of the extension table and should not reach toward the saw blade.
- Feed stock into the blade against the direction of its rotation.
- Move the rip fence out of the way when cross cutting. Never use it as a cut off gauge.
- Use a push stick when ripping narrow or short stock (e.g., when the fence is set less than about 15 cm (6 in) from the blade; when the piece is less than 30 cm (12 in) long or when the last 30 cm (12 in) of a longer piece is being cut). Refer to ripping applications in the manufacturer's instruction manual. See Woodworking Machines - Push Sticks for more information on push stick design.

- Use the push stick to remove the cut piece from between the fence and the blade.
- Keep hands out of the line of a saw blade.
- Use guard with a spreader (riving knife) and anti-kickback fingers for all ripping or cross cutting operations.
- Keep the body and face to one side of the saw blade out of the line of a possible kickback.
- Provide adequate support to the rear and sides of a saw table for wide or long stock.
- Be careful when waxing, cleaning, or servicing the table. Shut off and unplug (or lock out) a saw before doing any work on the saw.
- Keep area clean and clutter-free. Operate machines in a non-congested, well-lit area.
- Use the proper sawdust exhaust systems as required by operation.

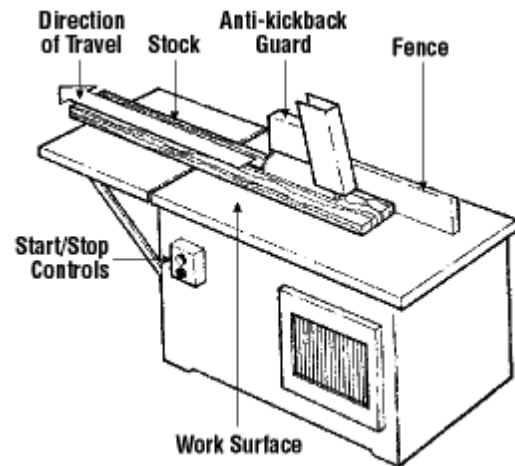

What should you avoid when working with a table saw?

- Do not saw freehand. Always hold the stock firmly against the mitre gauge or a rip fence to position and guide the cut.
- Do not reach around and over moving blades.
- Do not feed the work piece faster than the
- Do not leave a saw running unattended. Turn off the power and make sure the machine has stopped running before leaving the area.

t. Mitre Saw

What should you do before using a mitre saw?

- Mitre saws can be dangerous if not used properly.
 - Read the owner's manual carefully.
 - Make sure you know and understand the instructions before attempting to use any tool or machine.
 - Learn the applications and limitations before use.
-

What safety precautions should you follow when using a mitre saw?

- Wear safety glasses or goggles, or a face shield (with safety glasses or goggles).
- If work is dusty, use a respirator or dust mask.
- Wear appropriate hearing protection.
- Wear protective footwear when required.
- Attach the saw firmly on a workbench or other rigid frame and operate saw at waist height. The saw can also be taken to remote locations by mounting it on a piece of plywood 13 mm (1/2 in.) or thicker. This must be clamped to a waist high work surface on the job site with large "C" clamps.
- Keep one hand on the trigger switch and handle and use the other hand to hold the stock against the fence.
- Keep hands out of the path of the blade.
- Keep guards in place and in working order.
- Remove adjusting keys and wrenches.
- Use a crosscut or combination blade.
- Ensure that the blade rotates in the correct direction.
- Ensure that the blade and arbour collars are secure and clean. Recessed sides of collars should be against blade.
- Keep blade tight, clean, sharp and properly set so that it cuts freely and easily.
- Allow motor to reach full speed before cutting.
- Follow instructions for lubricating and changing accessories.
- Keep the work area clean. Cluttered areas and benches invite accidents.
- Keep the work area well lit.
- Reduce the risk of unintentional start-up. Make sure saw switch is in OFF position before plugging in.
- Unplug tools before servicing and when not in use.
- Check for damage. Repair or replace damaged parts.
- Keep motor air slots clean and free of chips.
- Use only the accessories designed for the specific saw and job.

What should you avoid when using a mitre saw?

- Do not operate the saw on ground.
- Do not cut pieces smaller than 20 cm (8 in.) in length.
- Do not cut "free hand." The stock should lie solidly on the table against the fence.
- Do not reach around or behind the saw blade.
- Do not take your hand away from the trigger switch and handle until the blade is fully covered by the lower blade guard.
- Do not overreach. Keep proper footing and balance at all times.
- Do not force the saw. The saw cuts better and more safely at the rate for which it was designed.
- Do not leave the saw until it has stopped completely. Turn the power off and unplug the saw.
- Do not use electric tools in damp or wet locations.
- Do not operate electric tools near flammable liquids or in gaseous or explosive atmospheres. Sparks may ignite fumes.



12. Safe Use of Specific Equipment - hand tools

a. Safe Use of Spanners and wrenches

What kinds of wrenches are there?

Wrenches are made in various shapes and sizes and are used for gripping, fastening, turning, tightening and loosening things like pipes, pipe fittings, nuts and bolts. There basically two major kinds of wrenches:

- Pipe wrenches used in plumbing for gripping round (cylindrical) things.
- General use wrenches used on nuts and bolts that have flat, parallel surfaces; e.g., square or hexagonal (hex).

Wrenches may be adjustable to fit different sized pipes, nuts and bolts or may be a fixed size.

What are some examples of adjustable wrenches?

Adjustable wrenches include:

- Pipe wrenches.
- Crescent (TM) wrenches which have adjustable jaws set at a 30 degree angle from the handle. Although Crescent is a trade name, it is widely used to refer to any regular adjustable wrench with an angled jaw regardless of who manufactured it.
- Monkey wrenches which have their adjustable head at a 90 degree angle from the handle.

What are some examples of fixed-size wrenches?

Fixed-sized wrenches include:

- Open ended wrenches that have "jaws" with parallel sides or tines that fit snugly on nuts and bolts.
- Closed end or box wrenches that have a loop at the end with notches on the inside that allow the wrench to fit either square or hex nuts or both (depending on the number of notches or points).
- Combination wrenches that have both an open end and a closed end on either end of the wrench; usually they fit the same size nut or bolt.
- Socket wrenches are like closed end wrenches except they are cylindrical in shape. They can fit over a nut in a recessed hole that would be inaccessible with open or closed ended wrenches. These have an offset handle at right angles to the nut being tightened or loosened. Usually the handle is a ratchet-type handle that allows the user to turn the socket continuously in one direction by moving the handle back and forth without having to take the socket off the nut.
- Torque wrenches, one type of socket wrenches, have a built-in spring-loaded indicator that shows how much torque being is being applied (i.e., shows how hard the nut is being tightened).
- Nut drivers, another type of socket wrenches, are sockets that can be snapped on or permanently fixed to a screwdriver-type handle.

- Allen wrenches or Allen keys are hexagon-shaped (six-sided) metal shafts that are bent into an L-shape for leverage. Hex drivers are "straight Allen wrenches" that have a screwdriver-type handle. These are different from the other wrenches since they fit inside a recessed hexagonal hole in screw heads instead of around a nut or bolt.

Fixed wrenches fit single, specific sizes. Metric wrench sizes are expressed as whole numbers (e.g., 8, 10, 14, 32) that correspond to the sizes in millimetres. Non-metric sizes used widely in the U.S. are also called S.A.E (Society of Automotive Engineers) sizes and are expressed as fractions of an inch; e.g., 1/4, 1/2, 3/4, 1 1/4. Since both metric and S.A.E. fasteners (nuts, bolts, etc.) are used in Canada, users must select the correct type and size of wrench to prevent injuries and damage to equipment in case of slippage when force is applied to the wrench.

What are general safety tips when using wrenches?

- Use the correct wrench for the job - pipe wrenches for pipes plumbing fittings, and general use wrenches for nuts and bolts.
- Discard any damaged wrenches (e.g., open ended wrenches with spread jaws or box wrenches with broken or damaged points).
- Select the correct jaw size to avoid slippage.
- Wear safety glasses or a face shield (with safety glasses or goggles) where there is a likely hazard of flying particles or falling debris.
- Position your body in a way that will prevent you from losing balance and hurting yourself if the wrench slips or something (e.g., a bolt) suddenly breaks.
- Use a box or socket wrench with a straight handle, rather than an off-set handle, when possible.
- Ensure that the jaw of an open ended wrench is in full contact (fully seated, "flat", not tilted) with the nut or bolt before applying pressure.
- When turning with an adjustable wrench, the direction of the turn should be against (towards) the permanent jaw.
- Ensure that the teeth of a pipe wrench are sharp and free of oil and debris and that the pipe or fitting is clean to prevent unexpected slippage and possible injuries.
- Apply a small amount of pressure to a ratchet wrench initially to ensure that the ratchet wheel (or gear) is engaged with the pawl (a catch fitting in the gear) for direction you are applying pressure.
- Support the head of the ratchet wrench when socket extensions are used.
- Pull on a wrench using a slow, steady pull; do not use fast, jerky movements.
- Stand aside when work is done with wrenches overhead.
- Make sure adjustable wrenches do not "slide" open during use.
- Keep tools well maintained (cleaned and oiled).
- Clean and place tools and wrenches in a tool box, rack or tool belt after use.

What should I avoid doing when using wrenches?

- Do not use push on a wrench - losing your balance is more likely if the wrench slips.
- Do not use a wrench that is bent handle or damaged.
- Do not use worn adjustable wrenches. Inspect the knurl, jaw and pin for wear.
- Do not pull on an adjustable wrench that is loosely adjusted.
- Do not use pipe wrenches on nuts or bolts.
- Do not use pipe wrenches for lifting or bending pipes.
- Do not use a wrench on moving machinery.
- Do not use the wrong tools for the job. Never use pliers instead of a wrench or a wrench as a hammer.
- Do not use a make-shift wrench.
- Do not insert a shim in a wrench for better fit.
- Do not strike a wrench (except a "strike face" wrench) with a hammer, or similar object, to gain more force.

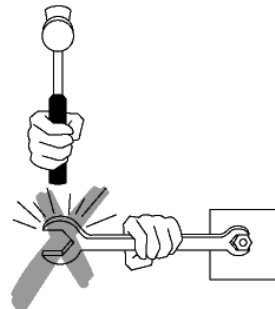

- Do not increase the leverage by adding sleeved additions (e.g., a pipe) to increase tool handle length.
- Do not expose a wrench to excessive heat (like from a blow torch) that could affect the temper of the metal and ruin the tool.

b. Gear Pullers

What are some safety tips for using gear pullers?

Gear pullers are made in various shapes and sizes and have many uses. Always use the correct tool for the job.

- Wear safety glasses or goggles, or a face shield (with safety glasses or goggles).
- Select the proper gear puller for each job. Always use a gear puller of the required size or larger. Use a 3-jaw puller, if possible.
- Ensure that the gear puller is aligned with the shaft and fits tightly around the part to be removed. The jaws should be parallel with the screw. This assures a straight pull.
- Be careful when removing a stubborn gear or bearing. Always strike the head of the centre screw squarely. If after two sharp blows the gear or bearing remains stuck, select a larger puller and proceed to remove the gear or bearing.
- Use a protective cap or removable point to protect screw from mushrooming or splitting.
- Stop work if the gear puller starts to deform.
- Cover work with a cloth to protect you and by-standers from flying parts.
- Lubricate the centre screw with machine oil before use.
- Clean the gear puller after use and store it in a dry place.

What are some things that I should avoid doing?

- Do not use air powered tools on gear pullers.
- Do not use any puller with functioning parts that show excessive wear, dents, or cracks. Inspect the centre screw for signs of galling or seizing.
- Do not heat any gear puller. It will lose its strength and break under pressure if heated.
- Do not cut or grind any part of a gear puller.

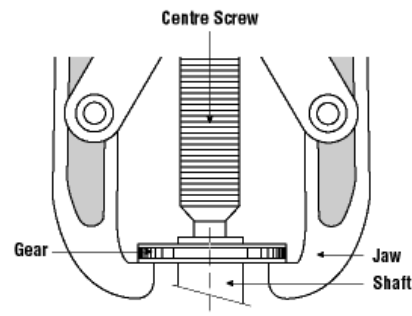

c. Vices

What should I know about using a vice?

A vice, sometimes called the third hand, is an indispensable tool in the tool room or workshop. Vices are usually mounted on workbenches or similar firm supports to hold material in place. Most vices can be used for a wide variety of work. Select the most suitable vice which is strong enough for the work.

- Wear safety glasses or goggles, or a face shield (with safety glasses or goggles) when using striking tools or power tools on a workpiece held by a vice.
- Attach a vice securely. Place bolts in all the holes in the base of the vice. Use lock washers under the nuts.
- Mount a vice so that the stationary jaw projects slightly beyond the edge of the workbench. This allows long work to be clamped in the vice without interference from the edge of the workbench.
- Ensure that the workbench is firmly secured to its base.
- Check the vice for cracks or other damage before clamping a workpiece in it.
- Use a vice large enough to hold the work without strain.
- Place the work piece in the vice so that the full clamping surface of the jaw supports the workpiece
- Keep the work piece in the vice close as possible to the jaws to prevent vibration when sawing, filing, etc.
- Support the end of extra-long work with an adjustable stand, saw horse, or box rather than putting extra strain on the vice.
- Keep all threaded and moving parts clean, oiled and free of chips and dirt.
- Use jaw liners in a vice where there is any possibility of marking the work.
- Replace a bent handle and worn jaw inserts.

What should I not do?

- Do not weld the base of the vice to any metal
- Do not repair a vice by welding or brazing
- Do not try to bend a heavy rod in a light vice.
- Do not cut into the jaws.
- Do not apply heavy pressure at the corner of the vice jaws.
- Do not use a handle extension (e.g., a pipe) for extra clamping pressure.
- Do not hammer on the handle to tighten beyond hand pressure.
- Do not use the jaws of the vice as an anvil.
- Do not use any vice that has the slightest crack.
- Do not unscrew or open the jaws of the vice wider than they were designed to be used.

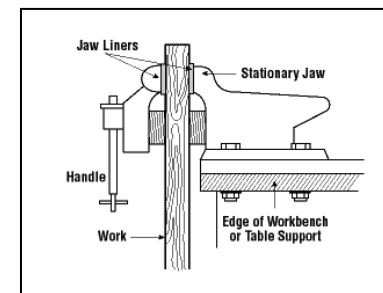

d. Wood Chisels

What are some safety tips to know when using a wood chisel?

Wood chisels are made in various shapes and sizes and for many uses. Use the correct chisel for the job.

- Wear safety glasses, or goggles, or a face shield (with safety glasses or goggles).
- Use the right size of chisel for the job.
- Choose smooth, rectangular handles that have no sharp edges and are attached firmly to the chisel.



- Ensure that the cutting edge is sharp. Dull chisels can be difficult to control and require more effort to do the job.
- Check stock thoroughly for knots, staples, nails, screws or other foreign objects before chiselling.
- Clamp stock so it cannot move.
- Adjust your stance so that you do not lose your balance if the tool slips.
- Chip or cut away from yourself.
- Keep your hands and body behind the cutting edge.
- Use a wooden or plastic mallet with a large striking face on all chisels. Only heavy-duty or framing chisels are made of a solid or moulded handle that can be struck with a steel hammer.
- Make finishing or paring cuts with hand pressure alone.
- Place chisels safely within the plastic protective caps to cover cutting edges when not in use.
- Replace any chisel that is bent or shows dents, cracks, chips, or excessive wear.
- Store chisels in a "storage roll," a cloth or plastic bag with slots for each chisel, and keep them in a drawer or tray.
- Replace broken or splintered handles.
- Sharpen cutting edges as often as necessary.

What should I avoid doing?

- Do not use a wood chisel as a pry or a wedge.
- Do not use a wood chisel on metal.
- Do not use an all-steel chisel with a mushroomed face or a chipped edge. Redress with a file or whetstone.
- Do not use a grinder to redress heat-treated tools. Use a whetstone.
- Do not use a dull chisel.

e. Clamps

What are examples of clamps?

Clamps are versatile tools that serve to temporarily hold work securely in place. They are used for many applications including carpentry, woodworking, furniture making, welding, construction and metal working.

Clamp styles include C-clamps, bar clamps, pipe clamps, and hand-screws. Bar clamps have adjustable arms that are easily widened or narrowed to fit the work piece and, therefore, requires fewer turns of the screw spindle, compared to a C-clamp, to hold the piece tightly.

Proper use of a **bar clamp**:

- Used for woodwork, especially for holding edges when gluing.
- Apply clamping pressure at right angles to the glue line otherwise slippage may result.

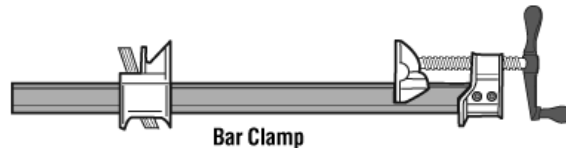

Proper use of a **c-clamp**:

- Used for carpentry, welding or cutting.

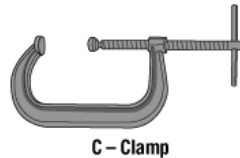

Proper use of a **hand screw clamp**:

- Can be made of metal or wood.
- Used to hold small pieces or in furniture repair.



What are some general safety tips to know when using clamps?

- Wear safety glasses or goggles, or a face shield (with safety glasses or goggles).
- Select the proper clamp style and size by matching the work-holding requirements of the job with the following clamp features:
- strength and weight (e.g., consider rail size and nominal clamping pressure)
- opening (length of reach)
- throat depth (depth of reach)
- ease of adjustment
- clamping surfaces (material used and size)
- Ensure that the swivel at the end of the screw turns freely before using.
- Dispose of clamps with bent frames; replace bent spindles, if possible.
- Ensure that the pressure plate and anvil parts of the clamp are in full contact with the workpiece before tightening.
- Close the jaws until the clamp feels tight. For example, when gluing, some glue will be squeezed out, a sign that it is tight enough.
- Use pads with C-clamps to avoid marking the work.

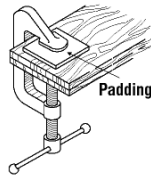

- Remove clamps as soon as the job is finished. Clamps serve only as temporary devices for holding work securely in place.
- Keep all moving parts of clamps lightly oiled and keep tools clean to prevent slippage. Also make sure there is no dirt or oil on any part that will come in to contact with the work.
- Store C-clamps by clamping them in a rack, not in a drawer.

What should I avoid doing?

- Do not use extra-large clamps just for the sake of their large throats. Instead, use, deep-throat clamps.
- Do not use any clamps that have a bent frame or a bent spindle.
- Do not use wrenches, pipes, hammers, or pliers to tighten clamps. Use wrenches only on clamps especially designed for wrenches.
- Do not hoist or pull with C-clamps. Use special lifting clamps.
- Do not use C-clamps to construct scaffolds or platforms for workers.

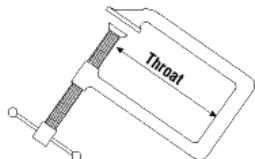

f. Basic Hand Tools

What are some basic tips when using hand tools?

- Always provide training on how to choose the right tool for the job, how to correctly use each tool, and how to identify when tools need repair.
- Select the right tool for the job. Substitutes increase the chance of having an accident.
- Use tools designed to allow wrist to stay straight. Avoid using hand tools with your wrist bent.
- Ensure that employees are properly trained in the safe use of hand tools.
- Use good quality tools.
- Keep tools in good condition at all times.
- Inspect tools for defects before use. Replace or repair defective tools.
- Keep cutting tools sharp and cover sharp edges with suitable covering to protect the tool and to prevent injuries from unintended contact.
- Replace cracked, splintered, or broken handles on files, hammers, screwdrivers, or sledges.
- Ensure that the handles of tools like hammers and axes fit tightly into the head of the tool.
- Replace worn jaws on wrenches, pipe tools and pliers.
- Redress burred or mushroomed heads of striking tools.
- Pull on a wrench or pliers. Never push unless you hold the tool with your palm open.
- Point sharp tools (e.g., saws, chisels, knives) lying on benches away from aisles and handles should not extend over the edge of the bench top.
- Maintain tools carefully. Keep them clean and dry, and store them properly after each use.
- Carry tools in a sturdy tool box to and from the worksite.
- Wear safety glasses or goggles, or a face shield (with safety glasses or goggles) and well-fitting gloves appropriate for the hazards to which you may be exposed when doing various tasks.
- Keep the work environment clean and tidy to avoid clutter which may cause accidents.
- Use a heavy belt or apron and hang tools at your sides, not behind your back.



What should I avoid when using hand tools?

- Do not use tools for jobs they are not intended to do. For example, do not use a slot screw drivers as a chisel, pry bar, wedge or punch or wrenches as hammers.
- Do not apply excessive force or pressure on tools.
- Do not cut towards yourself when using cutting tools.
- Do not hold the stock in the palm of your hand when using a cutting tool or a screwdriver.
- Do not wear bulky gloves to operate hand tools.
- Do not throw tools. Hand them, handle first, directly to other workers.
- Do not carry tools in a way that interferes with using both hands on a ladder, while climbing on a structure, or when doing any hazardous work. If working on a ladder or scaffold, tools should be raised and lowered using a bucket and hand line.
- Do not carry a sharp tool in your pocket.



g. Struck Tools

What are some safety tips to know when using a struck tool?

Struck tools are made in various shapes and sizes and for many uses and include cold chisels, punches, nail sets, rock and star drills, and wedges. Use the correct tool for the job.

- Wear safety glasses or goggles, or a face shield (with safety glasses or goggles).
- Use the tools only if they are good condition (i.e., cutting edges are sharp, struck head is not mushroomed or chipped).
- Hold the chisel, for shearing and chipping, at an angle which permits the bevel of cutting edge to lie flat against the shearing plane.

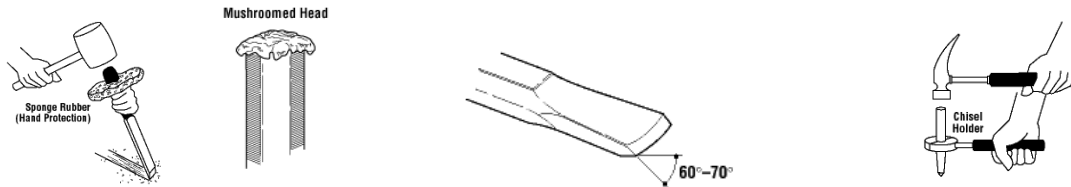

- Provide hand protection
- Hand protection can be provided by a sponge rubber shield forced onto the shaft of a chisel or select struck tools that come with hand protectors designed for the tool.
- Punch and chisel holders are also available.
- Discard tools which are bent, cracked or chipped.
- Redress striking tools with burred or mushroomed heads.
- Redress the point or cutting edge to its original shape. Grind to a slightly convex cutting edge. The point angle of the chisel should be 70° for hard metals, 60° for soft.

What should I avoid doing?

- Do not use struck tools if the struck end is chipped or mushroomed.
- Do not use struck tools if the cutting edge is dull or chipped or if the point of a punch is slanted or damaged.
- Do not apply too much pressure to the head when grinding a chisel. The heat generated can remove the temper.
- Immerse the chisel in cold water periodically when grinding.
- Do not use cold chisels for cutting or splitting stone or concrete.
- Do not use a drift pin punch (also called an aligning punch) as a pin punch intended for driving, removing, or loosening pins, keys, and rivets.
- Do not allow bull point chisels to be hand-held by one employee and struck by another. Use tongs or a chisel holder to guide the chisel so that the holder's hand will not be injured.

h. Pliers and Wire Cutters

What are common types of pliers and wire cutters?

Pliers are made in various shapes and sizes and for many uses. Some are used for gripping something round like a pipe or rod, some are used for twisting wires, and others are designed to be used for a combination of tasks including cutting wire. There are also tools that are used just for cutting wires (as opposed to wire cable and rope). Use the correct pliers or wire cutters for the job.

Proper use of **side cutting (lineman's) pliers**:

- Many applications including electrical, communications and construction work
- Use to grip, splice or cut wires, and strip insulation.

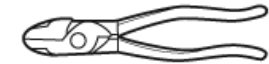

Side Cutting (Lineman's) Pliers

Proper use of **long nose pliers**:

- Use to grip small objects, reach awkward places, holding wires, bend loops, and attach wires
- Work involving smaller gauge wire.



Long Nose Pliers

Proper use of **utility pliers**:

- Use to grip round square, flat and hexagonal objects.
- Can apply limited torque (twisting force) without damaging the work.

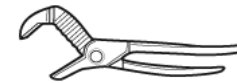

Utility Pliers

Proper use of **diagonal cutting pliers**:

- For work involving cutting and skinning wires, cutting and removing pins, nails and other fasteners.

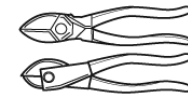

Diagonal Cutting Pliers

Proper use of **flat nose pliers**:

- Common pliers, used in many applications and assembly work.
- Use to grip, turn and bend wires.



Flat Nose Pliers

Proper use of **slip joint pliers**:

- Used to adjust nuts or bolts.



Slip Joint Pliers

Proper use of **end cutting pliers**

- Use for cutting wires, nails, rivets close to work.



End Cutting Pliers

What are some safety tips to know when using pliers and wire cutters?

- Wear safety glasses or goggles, or a face shield (with safety glasses or goggles) whenever there is a potential hazard from flying particles, pieces of wire, etc.
- Cut at right angles. Never rock the cutting tool from side to side or bend wire back and forth against the cutting edges.



- Choose pliers or wire cutters that have a grip span of 6 cm - 9 cm (2 1/2 - 3 1/2 in.) to prevent your palm or fingers from being pinched when the tools are closed.
- Use adjustable pliers that allow you to grip the work piece firmly while maintaining a comfortable handgrip (i.e., hand grasp is not too wide).
- Use tools only if they are in good condition.
- Make sure that the cutting edges are sharp. Dull and worn down cutting edges require many times more force needed for cutting.
- Make sure that the toothed jaws are clean and sharp. Greasy or worn down jaws can result in compromised safety. Such tools also require increased force to hold the workpiece which, in turn, increases the risk of muscular fatigue and repetitive strain injuries.
- Oil pliers and wire cutters regularly. A drop of oil on the hinge will make the tools easier to use.
- Pull on the pliers; do not push away from you when applying pressure. If the tools slips unexpectedly, you may lose your balance or hit your hand against equipment or something else hard that could result in an injury.

What should I avoid doing?

- Do not cut hardened wire unless the pliers or wire cutters are specifically manufactured for this purpose.
- Do not expose pliers or wire cutters to excessive heat.
- Do not bend stiff wire with light pliers. Needle nose pliers can be damaged by using the tips to bend large wire. Use a sturdier tool.
- Do not use pliers as a hammer.
- Do not hammer on pliers or wire cutters to cut wires or bolts.
- Do not extend the length of handles to gain greater leverage. Use a larger pair of pliers for gripping or a bolt cutter for cutting.
- Do not use cushion grip handles for jobs requiring tools with electrically insulated handles. Cushion grips are for comfort primarily and do not protect against electric shock.
- Do not use pliers on nuts and bolts; use a wrench.

i. Push Sticks

When should you use push sticks?

Push sticks or push blocks should be used when operating standard woodworking machinery, including table saws, band saws, radial arm saws, jointer/planers and shapers. These sticks protect the hand while allowing good hand control of the stock as it is pushed through the cutting head or blade. Push blocks for Jointer/Planers should be constructed for two-handed positioning.

- Always use a push stick for pieces less than 30 cm (1 ft) in length, or for the last 30 cm of a longer cut.
- Use the push stick to remove the cut piece from between the fence and the blade.

What are some features of a push block?

Hold-down push blocks should:

- be rigid
- enable the operator to protect both hands
- allow the operator to exert a firm and steady pressure on the work piece.

The following are samples of push blocks.

- Simple push sticks are useful on a table saw when distance between the blade and fence is narrow.
- ✓ Double-handled hold-down push block
- Frontal Push Block
- Side Push Block
- Use of two push blocks on single application

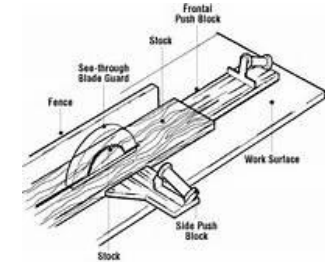
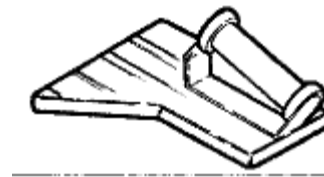
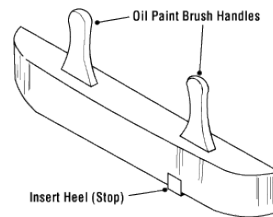
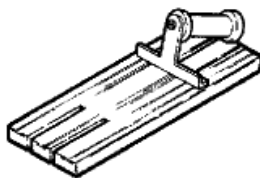
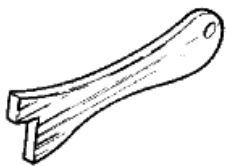

j. Non Sparking Tools

What is a "non-sparking" tool?

"Non-sparking", "spark reduced", "spark-resistant" or "spark-proof" tools are names given to tools made of metals such as brass, bronze, Monel metal (copper-nickel alloy), copper-aluminium alloys (aluminium bronze), or copper-beryllium alloys (beryllium bronze). Commonly used hand tools are often manufactured of steel alloys. Preferred "non-sparking" metals have less tensile strength than steels usually used to make tools. A lower tensile strength means the metal has less strength or resistance to tearing apart when stretched under test conditions. It also means that these tools are softer, wear down more quickly than ordinary steel tools, and have to be dressed more frequently.

What is the most important thing to know about "non-sparking" tools?

Non-sparking tools also generate sparks sometimes referred to as "cold sparks". These cold sparks have a low heat level and do not ignite carbon disulphide, which has the lowest ignition point of any substance known to man. Therefore while "non-sparking" tools may lower the risk of a spark, they do not eliminate the possibility of sparks. The name "non-sparking" is misleading because these tools are capable of producing a spark: the term "reduced-sparking tools" better describes these tools.

Non-metals like wood, leather, and plastic are suitable for some tools like shovels, scrapers or scoops and do not pose a friction spark hazard.

Non-sparking tools provide protection against fires and explosions in environments where there is a concern about sparks igniting flammable solvents, vapours, liquids, dusts or residues. There are many standards and recommendations that have been published by OSHA (Occupational Health and Safety Administration) and NFPA (National Fire Protection Association) that advise the use of non-sparking tools in hazardous environments.

NOTE: It is important to assess each situation carefully and use the appropriate tools for the hazards that are present. In some cases, "non-sparking" tools may still be able to produce a spark. Contact the tool manufacturer, and the producer of the flammable material (for example) for recommendations and more information.

What are the hazards of both "sparking" and "non-sparking" tools?

Both "sparking" and "non-sparking" materials can cause ignition. Two types of hazards are associated with tools manufactured of either material:

1. Ignition by friction, with impact on each other or on other materials such as steel or concrete, in which an "ordinary" (mechanical or frictional) spark is generated. All tools can ignite flammable mixtures by sparks generated by friction or impact. However, this is true only when the generated spark is incendive: that means a spark that has to have enough heat content (i.e., enough mass and sufficiently high temperature) and has to last long enough to heat a flammable air-vapour mixture above its ignition temperature. This is more likely in the case of sparks formed when using a metal grinder than a spark generated when a hammer strikes some metal.
2. Ignition by a chemically-generated spark, caused by impact between certain metals and some oxygen-containing substances (such as rust, which is iron oxide).

How should you use and maintain "non-sparking" tools?

Follow the guidelines below to reduce the risk of explosion and fire.

- Make sure all "non-sparking" tools are kept clean and free from ferrous or other contaminants, which may hamper the non-sparking properties.
- Do not use non-sparking hand tools in direct contact with acetylene, which may form explosive acetylides, especially in the presence of moisture.
- Use local or mechanical ventilation systems as appropriate to remove hazardous materials, dusts and vapours from the workplace.
- Follow normal safety procedures when sharpening non-sparking tools such as the provision of eye and face protection, adequate extraction and dust collection facilities.

What is the best safeguard against accidental explosions?

Follow safe work procedures. Always evaluate a job to be done in a hazardous environment (even the simplest one)! Use proper tools and equipment that eliminate ignition such as electric motors that can be certified as "explosion proof" for use in most hazardous work locations or non-sparking tools with proper use and maintenance.

Keep in mind that there are no truly non-sparking tools. In any work where flames are used, or sparks are produced, make sure that an explosive atmosphere does not develop. Such atmospheres include flammable vapour-air mixtures and organic dust clouds like flour or coal dust.

Isolation, ventilation and purging are methods of insuring a safe working atmosphere.

k. Hand Saws

What should I know about hand saws?

Saws are made in various shapes and sizes and for many uses. Use the correct saw for the job.

- Wear safety glasses or goggles, or a face shield (with safety glasses or goggles).
- Select a saw of proper shape and size for stock being used.
- Select a saw with the number of teeth per inch (TPI) in order to get the desired finish. For example: a coarse tooth blade (e.g., 2 or 3 TPI) should be used for thicker stock. 18 to 32 TPI should be used on thinner metals or plastic (0.5 cm or 1/4 inch). General wood cutting typically requires about 4 TPI.
- Choose a saw handle that keeps wrist in a natural position in the horizontal plane.
- Choose saw with a handle opening of at least 12 cm (5 in.) long and 6 cm (2.5 in.) wide and slanted at a 15° angle.

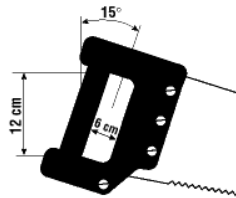

- Check the stock being cut for nails, knots, and other objects that may damage or buckle saw.
- Start the cut by placing your hand beside the cut mark with your thumb upright and pressing against blade. Start cut carefully and slowly to prevent blade from jumping. Pull upward until blade bites. Start with partial cut, then set saw at proper angle.
- Apply pressure on downstroke only.

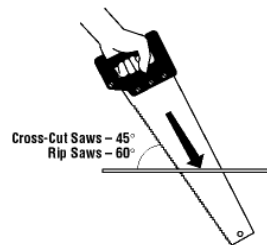

- Hold stock being cut firmly in place.
- Use a helper, a supporting bench or vice to support long stock if required.
- Keep teeth and blades properly set.
- Protect teeth of saw when not in use.
- Keep saw blades clean.

What should I know about using a hacksaw?

- Select correct blade for material being cut.
- Secure blade with the teeth pointing forward. Tighten the nut until the blade is under tension.
- Keep blade rigid, and frame properly aligned.
- Cut using steady strokes, directed away from you.

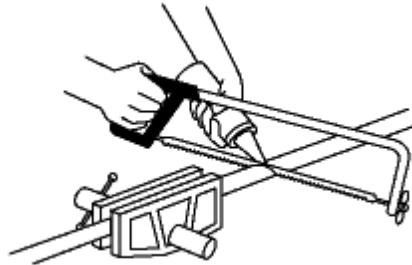

- Use entire length of blade in each cutting stroke.
- Use light machine oil on the blade to keep it from overheating and breaking.
- Cut harder materials more slowly than soft materials.
- Clamp thin, flat pieces requiring edge cutting.
- Keep saw blades clean and lightly oiled.
- Do not apply too much pressure on the blade as the blade may break.
- Do not twist when applying pressure.
- Do not use when the blade becomes loose in the frame

1. Snips

What are some safety tips to know when using snips?

Snips are made in various shapes and sizes for various tasks. The handle can be like those on scissors with finger and thumb holes or like plier handles. Models are available for cutting in straight lines, in curves to the left or curves to the right.

- Universal snips can cut in both straight and wide curves.
- Straight snips and duckbill snips (flat blade, "perpendicular" to the handle, with pointed tips) are designed to cut in straight lines; some duckbill snips are designed for cutting curved lines.
- Hawk's bill snips (with crescent-shaped jaws) are used for cutting tight circles.
- Aviation snips have compound leverage that reduces the effort required for cutting.
- Offset snips have jaws that are set at an angle from the handle.

DO

- Select the right size and type of snips for the job; check manufacturer's specifications about the intended use of the snips (e.g., type of cut - straight, wide curve, tight curve, right or left, and maximum thickness and kind of metal or other material that can be cut).
- Only use snips that are sharp and in good condition.
- Wear safety glasses or goggles, or a face shield (with safety glasses or goggles) and protective gloves when working with snips. Small pieces of metal may go flying in the air and the cut edges of metal are sharp.

Left cut snips are for making cuts to the left and straight cuts.

Right cut snips are for making straight cuts and cuts to the right.

Straight cut snips (not shown) are for making straight cuts and shallow cuts to the right or left.

Offset snips permit you to keep your hands safely above the cut while cutting directly through the centre of a large sheet.

- Use snips for cutting soft metal only. Hard or hardened metal should be cut with cutting tools designed for that purpose.
- Use ordinary hand pressure for cutting. If extra force is needed, use a larger tool.
- Cut so that the waste is on the right if you are right-handed or on the left if you are left-handed.
- Avoid springing the blades. This results from trying to cut metal that is too thick or heavy for the snips you are using.
- Keep the nut and the pivot bolt properly adjusted at all times.
- Oil the pivot bolt on the snips occasionally.

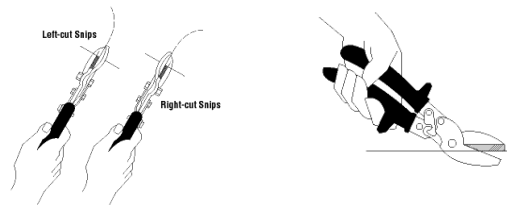

- Use the locking clip (if available) to keep the snips closed when not in use.

What should I avoid doing?

- Do not try to cut sharp curves with straight cut snips.
- Do not cut sheet metal thicker than the manufacturer's recommended upper limit (e.g., cuts up to 16 gauge cold rolled steel or 18 gauge stainless steel).
- Do not extend the length of handles to gain greater leverage.
- Do not hammer or use your foot to exert extra pressure on the cutting edges.
- Do not use cushion grip handles for tasks requiring insulated handles. They are for comfort primarily and not for protection against electric shocks.
- Do not attempt to resharpen snips in a sharpening device designed for scissors, garden tools or cutlery.

m. Cutting Tools for Bolts Cables and Strapping

What are some general safety tips to know when using cutting tools?

Many types and sizes of cutters are used for cutting selected metal products made from iron, steel, or softer, non-ferrous materials (e.g., copper, brass, aluminium). Cutters are designed to cut materials of different kinds of products such as wires, cables (electrical, coax, multi-strand), wire ropes, fencing, bolts, rods, pre-stressed concrete wires, and strapping.

- Wear safety glasses or goggles, or a face shield (with safety glasses or goggles) and protective gloves when using cutters.
- Choose the proper cutter for the job. Cutters are designed for a specific type, hardness, and size of material.
- Cut materials straight across - keep the material being cut at right angles to the cutting edges of jaws.
- Prevent injury from flying metal by wrapping a burlap bag, cloth or rag around the cutting jaws. Metal can fly when cut.
- Warn those in the area to take precautionary measures to avoid possible injury from flying metal pieces.
- Keep cutting tools in good repair
- Adjust and lubricate cutter and moving parts daily if heavily used.
- Sharpen jaws according to manufacturers' instructions.

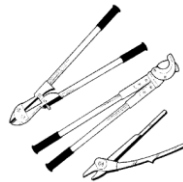

What should I avoid doing?

- Do not use a cutting tool until you are trained in its proper and safe use.
- Do not use cushion grip handles for jobs requiring insulated handles. Cushion grips are for comfort primarily and do not protect against electric shock.
- Do not use cutters which are cracked, broken or loose.
- Do not exceed the recommended capacity of a tool.
- Do not cut diagonally.
- Do not rock cutters from side to side when cutting wire.
- Do not pry or twist with tool when cutting.
- Do not hammer on cutting tools or extend the handle length to achieve greater cutting power.
- Do not expose cutters to excessive heat.
- Do not repair cutters. Discard equipment that is cracked, broken or shows signs of damage